



**Product Features**

- to protect drinking water against backflow of fluids up to and including category 4 according DIN EN 1717 / DIN 1988-100
- wetted parts made of stainless steel
- integrated differential pressure controlled and low-maintenance protection cartridge including CV
- with controllable reduced pressure zone
- flange connection
- with three assembled valves
- drain pipe connection from stainless steel HT 150
- inlet and outlet with check cartridge
- free from dead spots
- for horizontal installation, drain valve down
- maintenance requirements in accordance with DIN EN 806-5 must be complied with

**Standards and Approvals**

- DVGW approval
- according to accepted materials list from German environmental agency
- DIN 2576 / acc. to EN 12729 / EN 1717

**Technical Data**

- pressure rating PN 10
- max. operating temperature 60 °C
- min. primary pressure 0.15 MPa

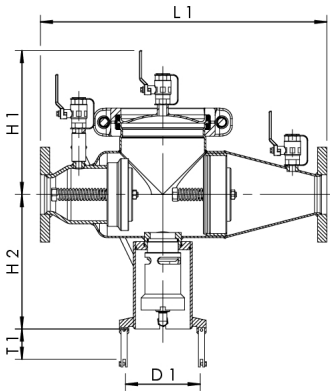

part no.	DN	bolt holes	D1 (mm)	H1 (mm)	H2 (mm)	L1 (mm)	T1 (mm)	kg
3610106500	65	4	146	310	270	559	60	32
3610108000	80	8	146	310	270	559	60	32,5
3610110000	100	8	146	310	300	559	60	33
3610115000	150	8	146	350	300	695	60	57

**accessory**

- backing ring for stub flange, figure 410 00
- stub flange, figure 425 00
- threaded flange, figure 426 00
- gasket, figure 428 00
- differential pressure measurement set, figure 360 99