



Product Features

- for hydraulic balancing of hot water return systems (PWH-C)
- wetted metal parts made from dezincification-free and corrosion-resistant gunmetal, resistant against aggressive water
- PTFE seat gasket
- maintenance-free spindle gasket with self-lubricating EPDM lip gasket
- female pipe thread
- with plugged drain port
- incl. thermometer
- with pocket for temperature sensor Pt1000
- free from dead spots
- keeps throttle pre-setting when valve is closed and opened
- with indicator for pre-setting

Standards and Approvals

- DVGW approval
- ÖVGW approval
- SVGW approval
- WRAS approval
- KIWA approval
- plastic parts with KTW and W 270 approval
- for systems according to DVGW worksheet W 551 / W 553 / DIN 1988-300
- according to accepted materials list from German environmental agency
- DIN EN 1213
- ÜA-Reg.-Nr. R-15.2.3-21-17048, WIEN-ZERT

Technical Data

- pressure rating PN 16
- max. operating temperature 100 °C

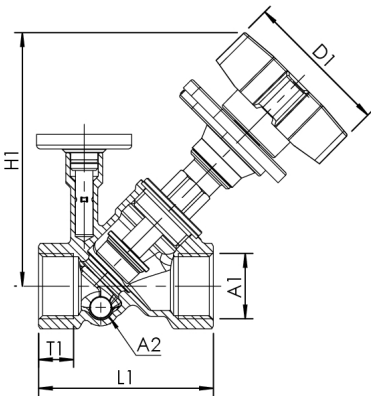

part no.	DN	A1	A2	D1 (mm)	H1 (mm)	L1 (mm)	T1 (mm)	cv (m³/h)	kg
1510601500	15	Rp 1/2	G 1/4	75,5	116	65	15	4,48	0,59
1510602000	20	Rp 3/4	G 1/4	75,5	123	75	16,3	6,28	0,769
1510602500	25	Rp 1	G 1/4	75,5	130,5	90	19,1	10,81	1,01
1510603200	32	Rp 1 1/4	G 1/4	75,5	130,5	110	21,4	15,56	1,467

accessory

- gunmetal sampling valve, figure 187 00
- insulation shell for MULTI-FIX-PLUS static balancing valve, as of 01/2017, figure 471 26
- drain valve made of gunmetal/plastic, figure J7109 173 00
- Pt 1000 temperature sensor, figure T5100 140 00